

Tangible Viewpoints: A Physical Approach to Multimedia Stories

Ali Mazalek

Interactive Cinema Group
MIT Media Laboratory
20 Ames Street, E15-368
Cambridge, MA 02139
1-617-253-1608

mazalek@media.mit.edu

Glorianna Davenport

Interactive Cinema Group
MIT Media Laboratory
20 Ames Street, E15-368
Cambridge, MA 02139
1-617-253-1607

gid@media.mit.edu

Hiroshi Ishii

Tangible Media Group
MIT Media Laboratory
1 Cambridge Center, 5th Floor
Cambridge, MA 02139
1-617-253-7514

ishii@media.mit.edu

ABSTRACT

We present a multimedia storytelling system that couples a tangible interface with a multiple viewpoint approach to interactive narratives. Over the centuries, stories have moved from the physical environment (around campfires and on the stage), to the printed page, then to movie, television and computer screens. Today, using wireless and tag sensing technologies, storytellers are able to bring digital stories back into our physical environment. The Tangible Viewpoints system explores how physical objects and augmented surfaces can be used as tangible embodiments of different character perspectives in an interactive tale. These graspable surrogates provide a direct mode of navigation to the story world, a means of bridging the gap between cyberspace and our physical environment as we engage with digital stories. The system supports stories told in a range of media, including audio, video, still image and text.

In this paper, we first provide a context for Tangible Viewpoints based on research in the areas of tangible interfaces and interactive narratives. We then offer an overview of the Tangible Viewpoints functionality, and explain the design and implementation of the system. The current system has been used in two storytelling projects. We discuss each one, and look at how user feedback has affected or will affect further development. We conclude by suggesting several future applications for the Tangible Viewpoints interface.

Keywords

Tangible interface, physical interaction, interactive narrative, multimedia storytelling, multiple point-of-view, character, design.

1. INTRODUCTION

Across the centuries, technological innovations have enabled the development of new mediums for creative expression, and artists

Permission to make digital or hard copies of all or part of this work for personal or classroom use is granted without fee provided that copies are not made or distributed for profit or commercial advantage and that copies bear this notice and the full citation on the first page. To copy otherwise, to republish, to post on servers or to redistribute to lists, requires prior specific permission and/or a fee.

Multimedia '02, December 1-6, 2002, Juan-les-Pins, France.
Copyright 2002 ACM 1-58113-620-X/02/0012...\$5.00.

and researchers have helped stories evolve to fit each one. Through experimentation, an understanding of past conventions, and a vision for the future of art, these "new medium pioneers" have defined expressive languages suited to emerging story delivery channels. Thus, we have seen stories transition from the physical environment (around campfires and on the stage), to the printed page, then to movie and television screens, and finally onto our computer screens.

Digital and multimedia technologies are progressively introducing authors and audiences around the globe to a variety of interactive storytelling experiences, ranging from virtual reality video games to hypermedia stories and role-playing games on the Internet. In parallel to the now familiar screen-based multimedia stories, today's story creators have the opportunity to bring digital stories back into our physical environment. Using wireless and tag sensing technologies, interactive narratives can make use of rich haptic interactions with physical objects, combining them with the power and flexibility of digital multimedia content processing and delivery.

In this paper, we introduce Tangible Viewpoints, an interface for multimedia storytelling that explores how physical objects and augmented surfaces can be used as tangible embodiments of different character perspectives in a multiple point-of-view interactive narrative. These graspable surrogates provide a direct mode of navigation to the story world, helping to bridging the gap between the realms of bits and atoms within the field of multimedia storytelling.

We believe that the Tangible Viewpoints interface can support a stronger psycho/physical relationship to the story world than is supported by more traditional graphical interfaces. Psycho/physical relationships can be defined as the way in which our external physical expressions affect our internal emotional life and vice versa. At present, this type of coupling is quite rare in our interactions with digital artifacts. Interfaces to cyberspace rely primarily on mouse/on-screen interaction to drive text, sound, images, video and 3D graphics. In contrast, Tangible Viewpoints provides a physical interface combining a game-board scale with pawns that are similar in size and shape to small dolls or chess pieces. This allows users to feel a stronger sense of identification with story characters than in purely screen-based storytelling systems.

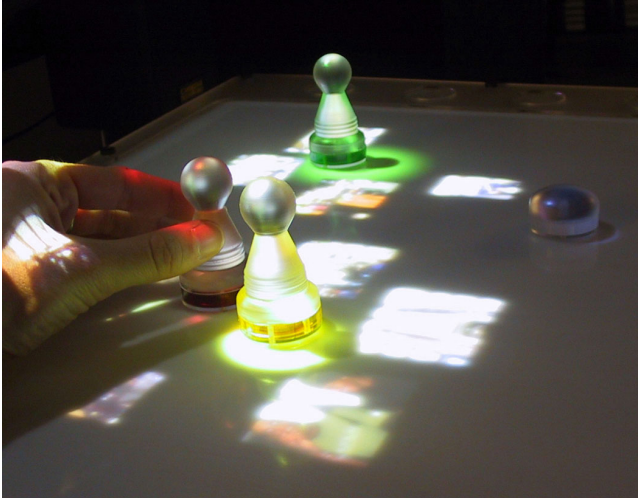

Figure 1. The graspable objects in the Tangible Viewpoints system.

Before giving an overview of the Tangible Viewpoints functionality, we begin by providing a context for the research, and looking at related work within the fields of tangible interfaces and interactive storytelling. We then discuss the design and implementation of the system, as well as two example storytelling projects. We conclude the paper with some ideas for future applications.

2. CONTEXT

As the name indicates, the Tangible Viewpoints system combines the use of tangible interface technology with a multi-viewpoint approach to storytelling. We believe that these two elements (tangible interface and multiple viewpoints) are synergistic and can work together to give users compelling and coherent story experiences.

2.1 Tangible Interfaces

All stories are told to and for an audience. When developing a story for a new channel, it is important to consider both the form and environment in which it will be conveyed to its audience. The environment needs to provide an atmosphere for immersion in the story world. Although graphical user interfaces allow us to manipulate information in a variety of ways, our interactions are constrained by the generic types of controllers we use, such as keyboards and mice. These devices force us to constantly shift our focus between our interaction with the device, and the on-screen display of information. Research in human-computer interaction has shown that this can be a source of confusion and delay [10, 11], and within the context of digital storytelling it can distract from the user's narrative experience. In contrast, tangible interfaces can provide users with a direct mode of navigation to the narrative world by coupling tangible controls with the representation of story information through projected graphics.

As human beings, we have developed sophisticated skills for sensing and manipulating our physical environment, most of which are not employed by traditional GUIs (graphical user interfaces). When we interact with a keyboard or mouse, we focus on the screen and the scale of the screen, often losing sight of the architecture or environment around us. Since tangible interfaces

are rooted in our physical surroundings, employing physical objects, surfaces and spaces as tangible embodiments of digital information, they can afford natural physical interactions with digital stories. Moreover, tangible interfaces can turn multimedia storytelling into a cooperative and social experience by allowing multiple users to interact with the same story, in the same space, and at the same time.

2.2 Multiple Viewpoints

In his book *Actual Minds, Possible Worlds*, Jerome Bruner writes: "Perhaps the greatest feat in the history of narrative art was the leap from the folktale to the psychological novel that places the engine of action in the characters rather than the plot." [4, p.37] Tzvetan Todorov makes a similar distinction between what he terms *apsychological* narratives (plot-centered) and *psychological* narratives (character-centered) [22].

In interactive storytelling, plot-driven stories can sometimes fragment the story or result in under-developed characters, leading to unsatisfying story experiences for viewers (e.g. choose-your-own-adventure stories). One possible alternative is to use multiple character viewpoints as a strategy for structuring user interactions into coherent story experiences. By allowing viewers to select the viewpoint as they navigate through an interactive story, a single story space can turn into a myriad of story experiences, each one tailored to the preferences of a particular individual or audience. Moreover, the notion of multiple viewpoints reflects our increasingly global society that keeps us constantly aware of the many different cultures and perspectives on life. By reshaping the stories we live by and capturing these many different viewpoints, we can keep evolving and redefining how we think, play and understand our lives.

3. RELATED WORK

The Tangible Viewpoints project is influenced by work from two main areas: the design of tangible interfaces for storytelling applications, and the creation of multiple viewpoint interactive narratives. The range of works within these areas is relatively broad. In this section, we take a brief look at a few notable and particularly relevant examples.

3.1 Tangible Narratives

The idea of using tangible components to tell interactive stories is far from new. Physical objects and environments (props and sets) can play an important role in both improvisational theatre and oral storytelling. They also figure heavily in the informal storytelling play that children engage in. Using their dolls and other toys as props, children have been telling (and participating in) tangible stories for centuries. As a result, much of the research into tangible narratives has been geared towards children. Many projects, such as StoryMat, use digital technologies to link children's stories to physical toys. In StoryMat, a physical play mat stores children's stories by recording their voices and the movements of the toys they play with [16]. These stories later revive on the mat as other children play and tell new stories using the same toys.

In the PETS project [8], an onscreen multimedia story building application is linked to a physical interface for the story delivery. Children can build a robotic toy pet out of modular components, and this pet can be used to act out the stories they have created in



Figure 2. A user viewing a story in the Tangible Viewpoints system.

the onscreen application. Also linking onscreen story creation with tangible delivery, researchers at the University of Nottingham used physical props in a classroom setting to encourage collaborative navigation through stories created in the KidPad software [1, 17].

In some cases, tangible interfaces provide a means for controlling a pre-existing storyline. In the TOONS project, tangible interaction tools, such as a magnetic board consisting of square tiles, are used to influence onscreen objects and streams in a television broadcast [18]. One of the goals of the project is to create an immersive broadcast experience by bringing part of the story into the child's own living environment. Another example of a tangible story controller is the Triangles interface [9, 10]. Flat triangular pieces that can be snapped together provide a means of navigating through a non-linear story. Finally, in the genieBottles project, a digital audio story is told by three genies that live in glass bottles [12, 13]. The physical action of uncorking the bottles releases the genies, and the story unfolds through conversations between them.

3.2 Multi-Viewpoint Interactive Stories

Alternating between different character perspectives as a story unfolds is a common technique in literature and film. It allows readers or viewers to gain access to different characters' thoughts and experiences, and use them as a contextual lens for understanding and interpreting the events in the story. In interactive storytelling, many systems also use multiple points-of-view as a means of structuring user interactions.

As early 1986, Carol Strohecker used character development to create an interactive narrative on videodisc [19]. The piece, entitled *A Different Train of Thought*, consists of a single story in which different characters see events in different ways, both literally and symbolically. Viewers interact with the story by accessing representations of the characters' thoughts.

Ten years later, Carol Strohecker, Kevin Brooks and Larry Friedlander returned to the idea of multiple points-of-view when they created *Tired of Giving In* [20, 21]. In this system, viewers explore the story through the perspectives of different characters and a three-part chorus based on Greek theatre. The authors call

their system an experiment in *narrative unfolding*, as the story is revealed not only through varying perspectives, but also at varying levels of detail that can be "unfolded" by the user.

During the story creation process, having multiple points-of-view allows authors to create rich story worlds. For instance, Agent Stories is a story design and presentation environment that supports non-linear multi-viewpoint stories [2, 3]. It allows story creators to build a framework for the story, including many different characters and events, and then use this framework to generate multiple narratives from the same collection of elements. Software agents act as the storytellers in the system, and can construct different styles of narratives based on their unique collections of behavioral traits. For instance, different agents will place the point-of-view in different characters, allowing the same story to be told from multiple perspectives.

Multiple point-of-view techniques have also been used to present varying perspectives within documentary material. For instance, the evolving documentary *New Orleans: A City in Transition* was a case study of urban change along the historic waterfront of New Orleans, which presented 5 major stories and 50 major characters across three years of development [5]. The system incorporated a free-form associative query mode for browsing information, and viewers could orchestrate which character's point-of-view they wanted to watch the action from.

4. FUNCTIONAL OVERVIEW

The Tangible Viewpoints system uses wireless graspable pawns to navigate through a multiple viewpoint story. When a pawn is placed on the interaction surface, the story segments associated with its character's point-of-view are projected around it in the form of small images or text titles. A small lens-like object serves as a selection tool for viewing the story content. By gliding this selection tool over particular story segments, users can playback their associated story content on a nearby monitor (see Figure 2), causing the narrative to advance and new segments to become available. The story content in Tangible Viewpoints can consist of various types of media (video, audio, images, text), and as such can present character development, action and location with as much complexity as any scene of a film or chapter of a book.

The narrative structure used in Tangible Viewpoints supports character-driven stories. That is, different characters with distinct personalities and unique points-of-view are used as the primary basis for creating the narrative. As the narrative unfolds, the system gathers information about which characters a user has been interacting with, and makes decisions about what segments to present based on this knowledge. If the user chooses to focus their interest on a particular character, the system narrows the story scope as it progresses, resulting in greater depth in that character's story. On the other hand, if the user spreads their focus between the three characters, the result is a much broader story.

When two pawns are touched together on the interaction surface, the system displays only the portions of story that are relevant to both characters. In this way, users can examine relationships between the characters and see how their individual stories or perspectives relate to one another.

5. SYSTEM ARCHITECTURE

The Tangible Viewpoints system consists of three main components: the tangible interface and display, the software engine, and a content database (see Figure 3). In this section, we describe the design and technical implementation of the first two components. Examples of content will be discussed in the Applications/Evaluation section.

5.1 Interface

The interface consists of two main sets of components, which provide the input and output for the Tangible Viewpoints system:

- (1) The interaction surface and tangible objects coupled with projection of graphics. These act as both input and output. The tangible objects (pawns and selection tool) provide a means of interacting with the story content, while the projected graphics provide information about the story state as the user interacts.
- (2) The flat-panel display and speakers. These are used for the playback of story content, in audiovisual form.

The system incorporates wireless sensing technology, which allows the tangible objects to be tracked as the user moves them around on the interaction surface. A sensing pad consisting of eight antenna loops is embedded inside the interaction surface, and the base of each tangible object contains a small electromagnetic resonator tag consisting of a wire inductance coil in parallel with a film capacitor. The tag data is sent to the computer via the serial port.

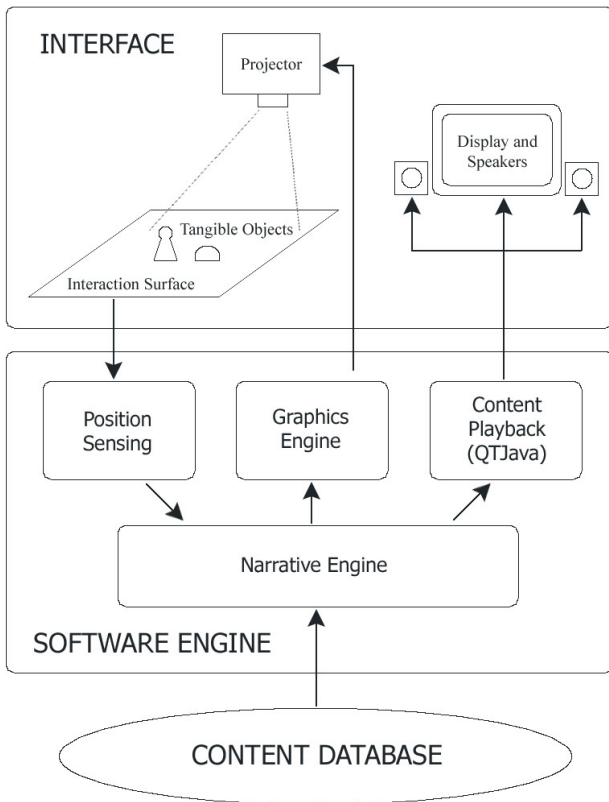

Figure 3. Tangible Viewpoints system diagram.

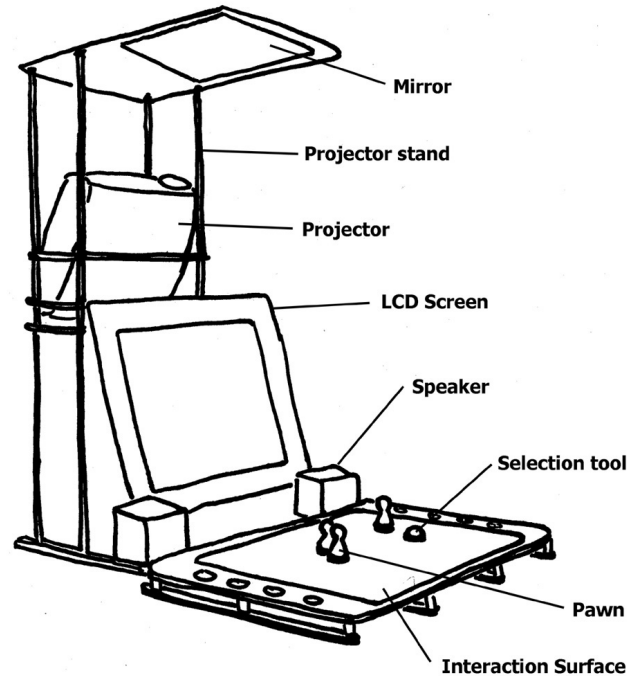

Figure 4. Interface setup diagram.

The design of the interaction surface was centered around a number of basic needs: the antenna coils and circuit boards needed to be concealed from view, there needed to be a clean surface on which the pawns could be moved and graphics projected, and finally it needed to be robust in order to withstand repeated use over a long period of time. The interaction surface was built using a Lasercutter with a combination of white, clear and translucent acrylic layers held together by screws. The topmost layer is used to create a raised border around the projection and sensing area of the interaction surface, giving users a tactile and visual indication of where the movement of the pawns can be sensed. The circular indentations along the sides serve as holders for the pawns when they are not being manipulated.

The design of the pawns that are used to represent the different character viewpoints was inspired by the pawns in a chess set. The abstract manner in which these figures evoke the human form allows them to take on different character roles given different sets of story content. Each pawn has a different color base that distinguishes it from others. The selection tool was designed to look like a small looking glass or lens. The pawns and selection tool were fabricated using a numerical control (NC) lathe.

Visual story content is displayed on a flat-panel screen, and any audio content is played through a set of stereo speakers. The screen and speakers are placed immediately behind the interaction surface, such that users will perceive them as an extension of the interaction space. A special projector stand was also constructed (see Figure 4), which allows the entire interface to be transported as a single unit.

5.2 Software Engine

The Tangible Viewpoints software is implemented in Java and consists of four main modules. By making the code modular, we can easily change one part of the system (such as the sensing technology, or the display mechanism) without affecting the rest of the program. The four modules are as follows:

- (1) The position sensing module is responsible for reading the tag data from the serial port.
- (2) The graphics module drives the projection of synchronized graphics onto the interaction surface.
- (3) The content playback module controls the display of audiovisual story content on a flat-panel screen and through stereo speakers.
- (4) The narrative engine reads in the story information and content. It interprets the data from the position module, and generates the appropriate response in the graphics and content modules. In short, it is responsible for moving the story forward based on user interactions. The details of its implementation are discussed in section 5.3.

The position sensing module uses a polling mechanism to gather resonant frequency information about each tag. Transmitted to the computer at 57,6 kbaud via the RS-232 protocol, this data is decoded into (x,y) positions for each tangible object.

The projected graphics include two components: the character auras, and the story segments (see Figure 5). The auras are used to give a visual representation of the prominence of each character's viewpoint in the current telling of the story. The colors of the auras match the colors of the pawns. The story segments represent pieces of narrative told from a certain character's viewpoint, and are displayed around their corresponding pawn. In order for the graphics to follow the pawns fluidly as they are moved around the sensing area, we implemented them as a physical simulation of a solar system. The pawns act as suns, and the story segments act as their planets. The planet are attracted to their own sun by a certain force, but repel all other planets as well as other suns.

A user can choose to playback a piece of narrative by gliding the selection tool over the corresponding story segment. The story content can consist of video, audio, images and text. The playback module was implemented using the QuickTime for Java API.

5.3 Computational Narrative Structure

The Tangible Viewpoints narrative structure supports multiple viewpoint narratives. When the program starts, the narrative engine begins by reading the story content from a database of story pieces (e.g. video clips, images with voice-overs, etc.). Each story piece is annotated with meta-data that indicates the character viewpoint, characters involved, and story time.

The narrative engine moves the story forward as users interact with the pawns. It combines a mechanism for maintaining story progression with a weighted network of story content.

5.3.1 Narrative Progression

In order to maintain narrative progression, Tangible Viewpoints stories are organized into acts, based on the three-act dramatic form that has evolved from ancient Greek theater (described in [15]). Most dramatic films and plays follow the three-act form.



Figure 5. The projected graphics. Each circle represents a character with an aura around it, and the images correspond to pieces of story. This content was created by kids at the Computer Clubhouse.

Act I sets up the story, past events, characters and conflict. Act II moves through a cause-effect chain of events and crises that often frustrate the characters, and generally concludes with a setback. Act III contains the climax and resolution of the story. The current Tangible Viewpoints implementation uses three principal character viewpoints and three acts, but could easily be expanded to include more.

User interactions cause the story to move forward through the three acts. As the story progresses, the system gathers information about which characters a user has been interacting with, and makes decisions about what segments to present based on this knowledge. For instance, imagine the user has been viewing segments from character A's viewpoint, and those segments have revealed story information about character B but not character C. In this case, when the story moves forward, only the segments involving either characters A or B will be presented. In this way, the system eliminates segments that do not contain information that is relevant to the current telling of the story. Depending on user interactions, the scope of a given telling of the story can thus become either progressively narrower (revealing more depth about one particular character) or progressively broader (revealing equal amounts of information about multiple different characters).

5.3.2 The Weighted Story Network

The use of a spreading activation network as a narrative engine was first seen in the Contour and Dexter systems [6, 7, 14]. Previous systems had generally used rule-based algorithms and a complicated annotation system as the underlying computational narrative structure. Contour and Dexter contain databases of video clips annotated with an arbitrary number of keywords grouped into classes. They present a clip selection algorithm based on thematic continuity (defined as the number of keywords two clips have in common). A spreading activation network of agents is used to monitor clips selected by the user and activate related clips, increasing the likelihood that they will be played in the future. While Contour and Dexter work well for documentary material, they are not tailored to convey a highly defined sense of narrative progression when navigating through the story content.

Some of the functionality of the Tangible Viewpoints narrative engine is based on this idea of a spreading activation network. However instead of giving users access to the entire database of story content, this weighted network is combined with the mechanism described in the previous section (5.3.1), which

eliminates non-relevant story segments from the viewable possibilities.

The meta-data of the story segments in Tangible Viewpoints (character viewpoint, characters involved, and story time) acts like the keywords in Contour and Dexter. In addition to this meta-data, each piece of story content is given an overall weight, which is similar to the activation value of the clips in Contour or Dexter. The story segments with higher weights figure more prominently on the interaction surface, indicating that they hold greater relevance to the current telling of the story, and increasing the likelihood that they will be selected (see Figure 6). If the weight of a story segment becomes negative, it will disappear from view altogether. As the user interacts with the story, the weights of the different story segments adjust themselves according to two rules:

- (1) When a user selects a story segment, the weights of all other segments seen from the same viewpoint and involving the same characters are increased.
- (2) As the story moves forward through the acts, the weights of all the story segments in the current act are increased, while those of segments in previous acts are decreased. The story segments from past acts thus become less prominent on the screen, giving users a sense of narrative progression and the passing of time.

5.3.3 Narrative Queries

The last important aspect of the Tangible Viewpoints computational narrative structure is its capability to support character-based narrative queries. By touching the pawns together, users can query the database of story segments according to character-based criteria. For instance, if the user touches the auras of two pawns together, the system displays only the story segments that are relevant to both of those characters. On the other hand, if the user touches the auras of all three pawns together, the system will display only the story segments that are relevant to all three at once. These narrative queries enable users to explore the story with respect to only the characters they are interested in by narrowing its scope as desired.

6. APPLICATIONS/EVALUATION

To date, the Tangible Viewpoints system has been used with two separate storytelling projects, discussed in sections 6.1 and 6.2. Section 6.3 suggests other possible storytelling applications for the interface.

6.1 A First Text-Based Story

The first story created for the Tangible Viewpoints system is entirely text based. It is a short multiple viewpoint narrative piece entitled *The Diner*, which tells the story of three characters from different walks of life who meet a diner in a small coastal town early one morning. Each character's experience of this encounter is different, shaped by their unique personality and perspective on life. By exploring the three viewpoints, users can gain access to the thoughts and feelings of the different characters, effectively seeing the story through each one's eyes.

The Diner is a relatively conventional multiple viewpoint story created by a single author. It served as a testing story during the design and implementation stages, allowing us to examine how the system would support simple multi-viewpoint stories in

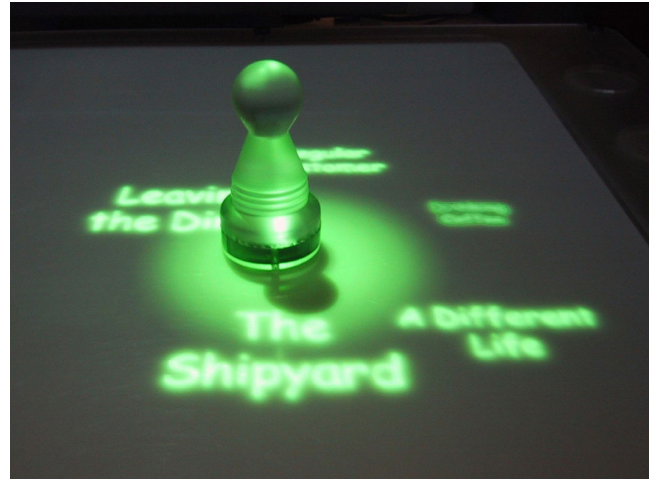

Figure 6. The story segments with larger weights are bigger in size and brighter, while those with smaller weights are smaller in size and faded.

practice. By having a set of story content ready at an early stage, we were able to pursue an iterative design process, gathering feedback from users in our laboratory, and progressively refining the interface and narrative engine during the development process.

The story was also presented in an "open house" setting at several major laboratory sponsor events. In these cases, people approached the system alone or in groups, and were free to interact with it as desired. During these sessions, we found that the physical layout of the interaction surface and the system's ability to support the manipulation of multiple pawns at once make Tangible Viewpoints well suited for collaborative story exploration. The main comment from users was that they wanted stronger clues as to which character's viewpoint they were seeing when the story pieces played back on the screen. This can be resolved by beginning the playback of each clip with an intertitle displaying the character's name, so that viewers would always be aware of the current viewpoint.

6.2 Telling Personal Stories

Tangible Viewpoints can also be used as a means of telling people's real-life stories. The system was used in a 10-day storytelling workshop at the Computer Clubhouse at the Boston Museum of Science in November 2001. Three participants were selected to create personal stories that would be played back in the system. All participants were teenage boys attending high school in Boston.

The three workshop participants began by working together to define a structure for their story. They decided on a documentary style narrative that would chronicle one day in each of their lives in Boston. Their individual story threads would progress from morning through evening, and would overlap at times when the boys' activities coincided (for instance in the lunchroom at school, or at the Computer Clubhouse). Each boy used a digital camera to take still images over the course of one day. The images were then organized, edited as needed, and added to the story database with the appropriate meta-data. The boys also provided voice-overs for their images.

The Tangible Viewpoints system was set up in the Clubhouse environment for the entire duration of the workshop, and members from the community were free to interact with the system and view the stories created by workshop participants at any time. In order to give viewers some content to interact with as soon as possible in the 10-day time span, the stories were loaded into the system at an early stage in the production process. The stories were then progressively refined over time by editing the images, adding new ones, adding voice-overs, tweaking the metadata, and re-ordering the clips. In this way, the storytelling process became a collaborative and iterative activity. By seeing their stories running in the system while they were still working on them, the boys could determine what changes needed to be made, and could get suggestions from their friends during the production process. This suggests that the Tangible Viewpoints system could be used as a tool for prototyping a story or for visualizing a large database of content during the early stages of production.

Like the story creation process, the story viewing was mostly a collaborative activity. Clubhouse members would gather around the system in groups and interact with the stories together (see Figure 7). They would frequently chat about the stories as they interacted, pointing things out to each other, and working together to explore the stories using the pawns and selection tool.

A number of ideas for future development on Tangible Viewpoints came from the observations taken during the workshop. We noticed that users often wanted to replay a story segment that they had already watched. In the current system, once a piece of content is played back on the screen, it disappears from the set of available story segments on the interaction surface. While this seems to make sense, since it allows the story to move forward and new segments to appear based on user interactions, it is clear that some way of reviewing story content should be made available to users. We would thus like to implement a timeline view of already viewed segments along the bottom of the interaction surface. A selected segment would move to the end of the timeline as it was played, and users could use the selection tool to review it if desired. The timeline view could also allow users to save a particular telling of the story whenever they finished, and over time they could build up a collection of linear stories representing different paths through the same story space.

The act structure that allows the system to maintain narrative progression proved to be a little too rigid for the somewhat free-form documentary style material created at the Clubhouse. In order to address this, future versions of the system could be made to support a more flexible structuring of narrative events.

Finally, the selection tool was somewhat limiting as a means of selecting content and moving the story forward, since only one person could be controlling it at a time. In order for navigation through the story space to be truly collaborative, it would be nice to eliminate the selection tool. Instead, the story could be made to unfold based on different types of user interactions, such as proximity of the pawns to one another, or their placement within specific areas of the interaction surface.

6.3 Additional Applications

We have discussed how Tangible Viewpoints has been used to tell a conventional text-based multi-viewpoint story, and the real-life image/audio-based stories of three teenage boys. We believe that

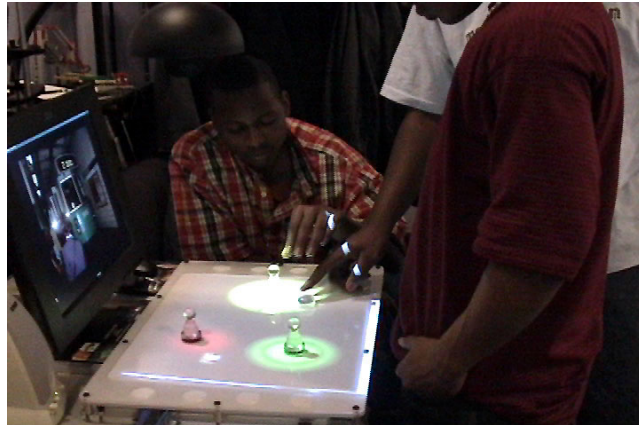

Figure 7. A group of kids interacting with Tangible Viewpoints at the Computer Clubhouse.

the tangible platform and multi-viewpoint storytelling approach could be extended for use in a variety of other storytelling applications and contexts as well. In this section, we take a brief look at three storytelling projects that are on the horizon for Tangible Viewpoints.

6.3.1 A Storytelling Tool for the Classroom

We have shown the Tangible Viewpoints platform to a number of teachers and educators, and have started thinking about how the system could be used in an educational context. The tangible and collaborative nature of the interface makes it particularly well-suited for use in a classroom or group setting. We envision a history teaching application, in which the pawns could provide different perspectives on a particular set of historical events. Manipulating the graspable pawns would allow children to take on different roles and identify with different historical points-of-view. The interface could thus be used to focus and guide classroom discussions on the topic, and the children could also add their own points-of-view to the system in the form of short video essays.

6.3.2 Storytelling in Rural Communities

Local storytelling and the sharing of observational stories within and between communities play an important role in both rural and urban cultures. We are beginning a project that will use constructionist methods for story development to tell learning stories in Indian rural communities, with the goal of encouraging a new generation of storytellers to evolve digital story forms appropriate to their environment. The Tangible Viewpoints platform will enable story creators to incorporate the many different perspectives that form the collective story fabric of their culture. The tangible interface is particularly appropriate, since it supports a genre of visual learning stories that may leapfrog the limitations of literacy encountered in many of these communities.

6.3.3 A Tangible/Acoustic Story Space

We are currently exploring the creation of an acoustic story space that uses the Tangible Viewpoints interface. Character dialogues, sound effects, and ambient background sounds are coupled with the projection of a visual landscape onto the interface surface. In this case, the projected graphics give users an idea of the story's physical environment. The story audio is then mapped to different parts of the stereo field based on the pawns positions and

movements on the interaction surface, creating a "tangible soundscape" for the story that enhances the projected visual landscape.

7. CONCLUSION

In this paper we presented a new approach to multimedia storytelling that incorporates a multiple viewpoint narrative model with a tangible platform for interacting with the story. By using wireless sensing technologies and the projection of graphics together with a screen-based display and audio output, Tangible Viewpoints brings the richness of haptic interactions from the physical world into the realm of digital storytelling.

Tangible Viewpoints uses physical pawns as handles on the character viewpoints in an interactive narrative. The system supports stories told using a variety of media types, such as images, audio, video and text. The movement of the graspable surrogates on the interaction surface provides users with a direct mode of navigation to the story world, which can create a strong sense of identification with the different characters and their varying perspectives.

The collaborative and tangible nature of the interface lends itself well to a variety of contexts and settings, and we have suggested possible applications within classrooms, rural communities, and artistic environments. We believe that this type multi-viewpoint tangible system supports a stronger connection to the story world than traditional screen-based systems, helping to bridge the gap between our physical world and cyberspace within the field of multimedia storytelling. While we do not as yet know the exact extent of this psycho/physical coupling, we feel that it is an important question that will form the basis for future exploration and development on Tangible Viewpoints.

8. ACKNOWLEDGMENTS

Many people have contributed to this work. We would like to thank the members of the Interactive Cinema and Tangible Media groups at the MIT Media Laboratory. We would also like to thank Jason Alonso, Egon Pasztor, and Dan Overholt for their help with software and hardware implementation.

9. REFERENCES

- [1] Benford, S., et al. "Designing Storytelling Technologies to Encourage Collaboration Between Young Children" in *Proceedings of CHI '00*, ACM Press, pp.556-563.
- [2] Brooks, Kevin. "Agent Stories" in *AAAI Spring Symposium Series –Interactive Story Systems, Plot and Character*. American Association for A.I., Stanford University, 1995.
- [3] Brooks, Kevin. "Do Story Agents Use Rocking Chairs? The Theory and Implementation of One Model for Computational Narrative" in *Proceedings of ACM Multimedia '96*, ACM Press, Boston, MA, 1996, pp.317-328.
- [4] Bruner, Jerome. *Actual Minds, Possible Worlds*. Harvard University Press, Cambridge, MA, 1987.
- [5] Davenport, Glorianna. "New Orleans in Transition, 1983-1987: The Interactive Delivery of a Cinematic Case Study" in *Proceedings of the International Congress for Design and Planning Theory, Education Group Conference*, May 1987.
- [6] Davenport, G., Murtaugh, M. "ConText: Towards the Evolving Documentary" in *Proceedings of ACM Multimedia '95*, November, 1995.
- [7] Davenport, G., Murtaugh, M. "Automatist Storyteller Systems and the Shifting Sands of Story" in *IBM Systems Journal*, vol.26, no.3, 1997, pp.446-56.
- [8] Druin, A., et al. "Desiging PETS: A Personal Electronic Teller of Stories" in *Proceedings of CHI '99*, ACM Press, 1999.
- [9] Gorbet, M. *Beyond Input Devices: A New Conceptual Framework for the Design of Physical-Digital Objects*. MS Thesis, MIT Media Lab, 1998.
- [10] Gorbet, M., Orth, M., Ishii, H. "Triangles: Tangible Interface for Manipulation and Exploration of Digital Information Topography" in *Proceedings of CHI '98*, ACM Press, pp. 49-56.
- [11] Ishii, H., Ullmer, B. "Tangible Bits: Towards Seamless Interfaces between People, Bits and Atoms" in *Proceedings of CHI '97*, ACM Press, pp. 234-241.
- [12] Mazalek, A. *Tangible Interfaces for Interactive Point-of-View Narratives*. MS Thesis, MIT Media Lab, 2001.
- [13] Mazalek, A., Wood, A., Ishii, H., "genieBottles: An Interactive Narrative in Bottles" in *Conference Abstracts and Applications of SIGGRAPH '01*, ACM Press, p.189.
- [14] Murtaugh, M. *The Automatist Storytelling System: Putting the Editor's Knowledge in Software*. MS Thesis, MIT Media Lab, 1996.
- [15] Richards, Ron. *A Director's Method for Film and Television*. Focal Press, 1992.
- [16] Ryokai, K., Cassell, J. "StoryMat: A Play Space with Narrative Memory" in *Proceedings of IUI '99*, ACM Press, 1999.
- [17] Stanton, D., et al. "Classroom Collaboration in the Design of Tangible Interfaces for Storytelling," in *Proceedings of CHI '01*, ACM Press, pp.482-489.
- [18] Stienstra, Marcelle. "Creating an Immersive Broadcast Experience" in *Proceedings of ACM Multimedia '01*. ACM Press, pp.455-456.
- [19] Strohecker, Carol. *Electronic Collage: The Videodisc and Interactive Narrative*. MS Thesis, MIT Media Lab, 1986.
- [20] Strohecker, C. "Tired of Giving In: Experimenting with the Greek Chorus as a Model for Interaction with Stories" in *Nov'Art: Les Etats Generaux de l'Ecriture Multimedia*. ART3000, Paris, 1996.
- [21] Strohecker, C., Brooks, K., Friedlander, L. "Tired of Giving In: An Experiment in Narrative Unfolding." Available as *Technical Report 99-16*. Cambridge MA: MERL - A Mitsubishi Electric Research Laboratory, 1999.
- [22] Todorov, Tzvetan. "Narrative Men" in *Poetics of Prose*. Translated by Richard Howard. Cornell University Press, Ithaca, NY, 1977.